













# CJ-29D Series Enviro Day/Night Infrared Cameras



-  1/3" CCD Sony Super HAD image sensor
-  350 lines of resolution
-  0 lux with IR LED on
-  Automatic electronic shutter
-  Weatherproof housing (IP-66)
-  12vdc operation
-  Built-in 4.0mm fixed IR lens
-  2" dia x 2 3/4" l
-  Removable sunshield and mount
-  CJ-29DF-12 – 12 IR w/ 4.3mm fixed – up to 32 feet
-  CJ-29DF-24 – 24 IR w/ 12mm fixed – up to 98 feet
-  CJ-29DS-36 – 36 IR w/ 4-9mm varifocal – up to 98 feet



**CREST**  
ELECTRONICS INC  
Video Security Since 1974

# Product Data: CJ-29D Series Enviro Day/Night Infrared Cameras

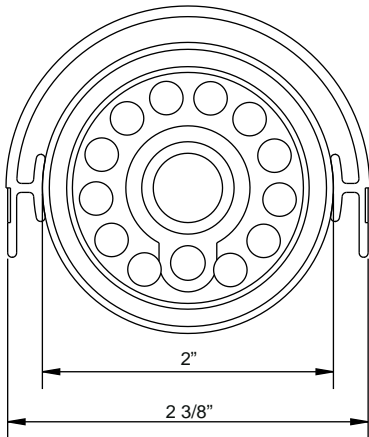

Front View (LED 12 pieces)

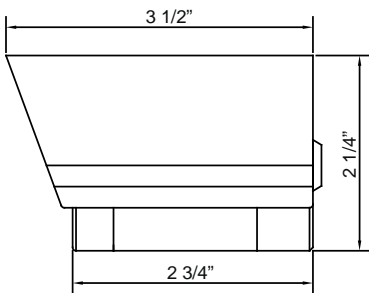

Side View

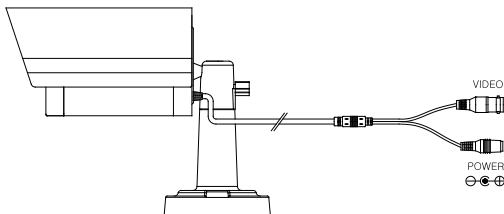

<b>Model Number</b>	<b>CJ-29D Series</b>
<b>Product Description</b>	Color Day/Night Infrared Camera
<b>Image Pick-Up Device</b>	1/3" CCD Sony Super HAD
<b>Horizontal Resolution</b>	350 TV Lines
<b>Minimum Illumination</b>	0 Lux (IR LED on)
<b>S/N Ratio</b>	More than 48dB (AGC off)
<b>Auto Electronic Shutter</b>	NTSC: 1/60-1/100,000s
<b>Auto Gain Control</b>	Yes
<b>Auto White Balance</b>	Yes (2500-9500K)
<b>Scanning System</b>	Interlace 2:1
<b>Gamma Characteristic</b>	0.45
<b>Lens Furnished</b>	IR lens 4.0mm
<b>Synchronous System</b>	Internal, negative sync
<b>Video Output</b>	1 Vp-p / 75 ohms, BNC connector
<b>Infrared Luminary</b>	12 pieces (DF-12); 24 pieces (DF-24); 36 pieces (DS-36) IR LED; Life: 6000 hrs
<b>Wave Length</b>	850nm
<b>Beam Spread</b>	35K
<b>Projection Distance</b>	Up to 32 feet (DF-12); Up to 98 feet (DF-24 & DS-36)
<b>Auto Power ON/OFF</b>	Cds auto control
<b>Illumination Active Limit</b>	Under 10 lux
<b>Power Supply</b>	DC 12v +/-10%
<b>Power Consumption</b>	220mA min (Camera+IR LED ON)
<b>Operating Temperature</b>	14 ~ 122°F
<b>Dimensions</b>	2" Dia x 2 3/4" L

Specifications subject to change

